

## Specifications

### OPERATING PERFORMANCE

Operating Weight	Canopy 12,450 lb (5,647 kg)
	Standard Machine with Bucket and Rubber Tracks Cab 12,681 lb (5,752 kg)
Maximum Digging Depth	12 ft 10 in (3,900 mm)
Maximum Dump Height	12 ft 9 in (3,885 mm)
Maximum Reach	20 ft 4 in (6,195 mm)
Maximum Bucket Digging Force	11,093 lb (5,032 kg)
Maximum Arm Digging Force	5,670 lb (2,572 kg)
Arm Length	5 ft 9 in (1,760 mm)
Slew Speed	10 rpm
Traction Force	12,613 lb (5,721 kg)

### ENGINE

Make/Model	Yanmar/4TNV88
Tier Rating	Interim Tier 4
Cylinders/Displacement	4/134 cu in (2.2 L)
Horsepower Gross (SAE J1995)	39.7 hp (29.6 Kw)
Horsepower Net (SAE 1349)	38.7 hp (28.9 Kw)
Rated Engine Speed	2,400 rpm
Maximum Torque	105 ft-lb @ 1,440 rpm (143.4 Nm)
Engine Lubrication	8.0 qt (7.50 L)
Cooling System	9.3 qt (8.8 L)
Fuel Tank Capacity	17.2 gal (65 L)
Fuel Consumption (65% of Full Load)	1.8 gal/hr (6.8 L/hr)
Electrical System	12 volts / 40 amps

### UNDERCARRIAGE

Traction Drive Type	Planetary Reduction and Auto Shift Down
Parking Brake	Spring Applied, Hydraulically Released, Multiple Wet Friction Disc
Track Roller Type	Permanently Sealed, Triple Flanged Rollers
Track Rollers	5 per side
Track Width	15.7 in (400 mm)
Track Ground Contact Length	6 ft 6 in (1,985 mm)
Ground Pressure	Canopy 4.6 psi Cab 4.7 psi
Maximum Travel Speed	
Low Range	1.7 mph (2.7 km/hr)
High Range	3.1 mph (5.0 km/hr)

### HYDRAULIC SYSTEM

Pump Type	Variable Displacement Piston Pumps x 2 and Gear x 2
Total Hydraulic Flow	42.8 gal/min (62 L/min)
Auxiliary Hydraulic Flow	25.6 gal/min (96.9 L/min)
System Operating Pressure	3,000 psi (20.6 mpa)
Hydraulic Reservoir Capacity	18 gal (68.1 L)
Hydraulic System Capacity	21.9 gal (110 L)



### WORKING DIMENSIONS

A. Maximum Reach	20 ft 4 in (6,195 mm)
B. Maximum Reach Ground Level	19 ft 10 in (6,065 mm)
C. Maximum Dig Depth	12 ft 10 in (3,900 mm)
D. Maximum Vertical Dig Depth	9 ft 11 in (3,030 mm)
E. Maximum Dig Height	18 ft 0 in (5,490 mm)
F. Maximum Dump Height	12 ft 9 in (3,885 mm)
G. Blade Maximum Lift	12.6 in (320 mm)
H. Blade Maximum Lower	12.8 in (325 mm)

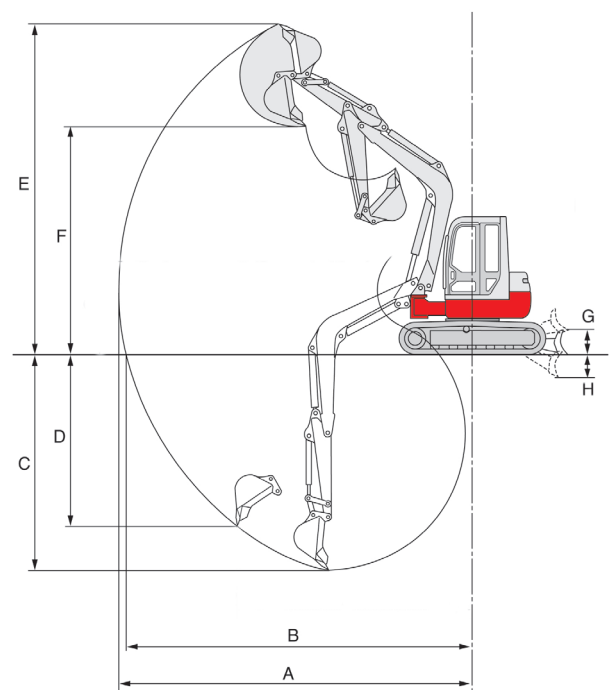

**MACHINE DIMENSIONS**

A. Transport Length	17 ft 7 in [5,350 mm]
B. Undercarriage Width	6 ft 7 in [2,000 mm]
C. Transport Height	8 ft 6 in [2,585 mm]
D. Tail Swing (Slew) Radius	3 ft 8 in [1,110 mm]
E. Counter Weight Ground Clearance	2 ft 0 in [615 mm]
F. Track Ground Contact Length	6 ft 6 in [1,985 mm]
G. Undercarriage Length	8 ft 2.5 in [2,500 mm]
H. Track Width (Rubber)	15.7 in [400 mm]
J. Ground Clearance	11.8 in [300 mm]
K. Minimum Front Radius	4 ft 3 in [1,285 mm]
L. Offset Working Distance (Left)	2 ft 4.3 in [720 mm] @ 30°
M. Offset Working Distance (Right)	2 ft 8.5 in [825 mm] @ 15°
P. Dozer Blade Width	6 ft 7 in [2,000 mm]
Q. Dozer Blade Height	16.9 in [430 mm]

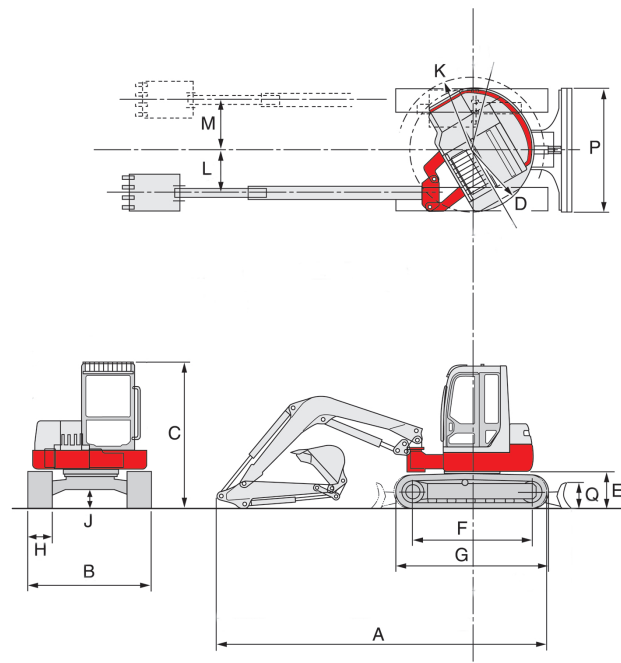

◆ - Standard

○ - Optional

# Product Features

**ENGINE**

- ◆ EPA Interim Tier 4 Compliant
- ◆ Automatic Fuel Bleed System
- ◆ Extended Life Coolant
- ◆ Dual Element Air Cleaner

**ELECTRICAL**

- ◆ Electronic Monitoring System that Includes Visual and Audible Alarms for Low Oil Pressure, High Engine Coolant Temperature, Air Cleaner Restriction, and Charge Level
- ◆ 12 volt System with 40 amp Alternator
- ◆ Work Lights: Boom, Side Cover
- ◆ Engine Preheat
- ◆ Hour Meter
- ◆ Travel Alarm

**UNDERCARRIAGE AND FRAME**

- ◆ Triple Flange Track Rollers
- ◆ Sloped Frame with Open Centers
- ◆ 2-Speed Travel with Automatic Shift
- ◆ Heavy Duty Dozer Blade
- ◆ Cast Iron Wrap Around Protective Counterweight
- ◆ 15.7 in Rubber Tracks

**HYDRAULIC**

- ◆ Cushioned Main Boom and Arm Cylinders
- ◆ Precise and Responsive Pilot Controls
- ◆ Primary Auxiliary Hydraulic Circuit Plumbed to Arm with 1-Way and 2-Way Operation
- ◆ Accumulator
- ◆ Hydraulic Oil Cooler with Sight Gauge
- High Flow Primary Auxiliary Hydraulics 25.6 gal/min

**WORKING EQUIPMENT**

- ◆ Main Boom Cylinder Guard
- ◆ Patented Side-to-Side (STS) Offset Boom System
- ◆ Long Arm
- ◆ Boom Holding Valve with Overload Alarm
- Dual Pin Position Bucket
- Mechanical Bucket Quick Coupler
- Main Pin Hydraulic Thumb

**OPERATOR'S STATION**

- ◆ ROPS/TOPS/FOPS Four Post Canopy
- ◆ Tilt-up Operator Station for Outstanding Service Access
- ◆ Six Way Adjustable Suspension Seat with Adjustable Arm Rests
- ◆ Quick Change Control Pattern (ISO or SAE)
- ◆ Proportional Slide Switch for Auxiliary Hydraulics
- ◆ 2 in Retractable Seat Belt
- 3 in Seat Belt
- Cab with Air Conditioner, Heat, Defrost, Windshield Wiper and Washer, AM/FM/Mp3 Radio